



# Wombat Counting Scale

AWE's Economical Counting Scale. Ideal For Your Stock Inventory Control Management of Small Parts



Wombat Counting Scale



Australian Weighing Equipment Offers Industrial Weighing Solutions Built To Last



## Wombat Counting Scale

### The Wombat Counting Scale

AWE's Economical Counting Scale. Ideal For Your Stock Inventory Control Management of Small Parts. Take the guesswork out of counting, tedious little parts with AWE's Wombat Series Counting Scale. Our Wombat Counting Scale, offers, high resolution counting scales with an affordable price tag. Quickly weigh or count accurately, small pieces at a fraction of the time with the Wombat Counting Scales.

The Wombat Counting Scale is a robust and cost-effective solution for managing your stock control needs. Designed for portable use with a built-in rechargeable battery pack.

- ▶ Responds quickly with accurate weights
- ▶ Application:
  1. Piece counting
  2. Preset tare
  3. Piece checking alarm
  4. Accumulation
- ▶ Counting method:
  1. Sample
  2. Enter unit weight
  5. 10-unit weigh memory function

### Manage Your Stock Inventory Control of Small Parts

If you have the boring task of counting, quantities of identical pieces like; screws, nuts, bolts or parts, then you need a Wombat Counting Scale. If you're still using manual counting for Stock Control Inventory, then it's highly likely these will not be an accurate count. Manual counting is prone to errors, because of the tedious, time consuming nature of counting small parts, one by one.

The Wombat Counting Scale, works by weighing a sample and averaging it by weight. So you'll find the Wombat Counting Scales the most economical solution to increasing productivity & reducing your labour costs, of counting small objects.

### What You Get With The Wombat Counting Scale

The Wombat features a Reverse Sampling Counting method which enables a count to be taken when stocktaking from full containers of a known tare weight. An unknown quantity of volume sample can be determined by entering the unit weight or piece weight.

- ▶ Capacities from 3kg to 30kg
- ▶ **Stainless steel Pan 300mm x 230mm**
- ▶ Internal Resolution 1/600,000, means you accurately very small parts
- ▶ **Responds quickly with accurate weights**
- ▶ Application programs included: piece counting, preset tare, piece checking alarm, accumulation
- ▶ **Battery provides up to 70 hours of continuous use (without backlight to save power)**



Wombat Counting Scale

Australian Weighing Equipment Offers Industrial Weighing Solutions Built To Last

## Wombat Counting Scale Specifications



<b>Order Code</b>	WOMBAT-S2-3KG	WOMBAT-S2-6KG	WOMBAT-S2-15KG	WOMBAT-S2-30KG
<b>Capacity</b>	3kg	6kg	15kg	30kg
<b>Resolution</b>	0.1g	0.2g	0.5g	1g
<b>Max Division</b>	30,000d			
<b>Pan Size</b>	230 x 300mm			
<b>Gross Weight</b>	5kg			
<b>Display</b>	20mm digit LCD display, with white LED backlight			
<b>Keyboard</b>	20 keys (Membrane keyboard)			
<b>Housing</b>	ABS Plastic			
<b>Power</b>	AC adapter (12V/500mA), Internal rechargeable battery (6V/3.2Ah)			
<b>ADC Update</b>	≤1/10 second			
<b>Operating Temp</b>	-10°C~+40°C			
<b>Approvals</b>	CE			

## Wombat Counting Scales Options

Order Code	Description
PS-101	Spare Power Packs for Recharging 12v500mA
	RS232 Interface
	Initial-Verification

## Wombat Counting Scale Specifications

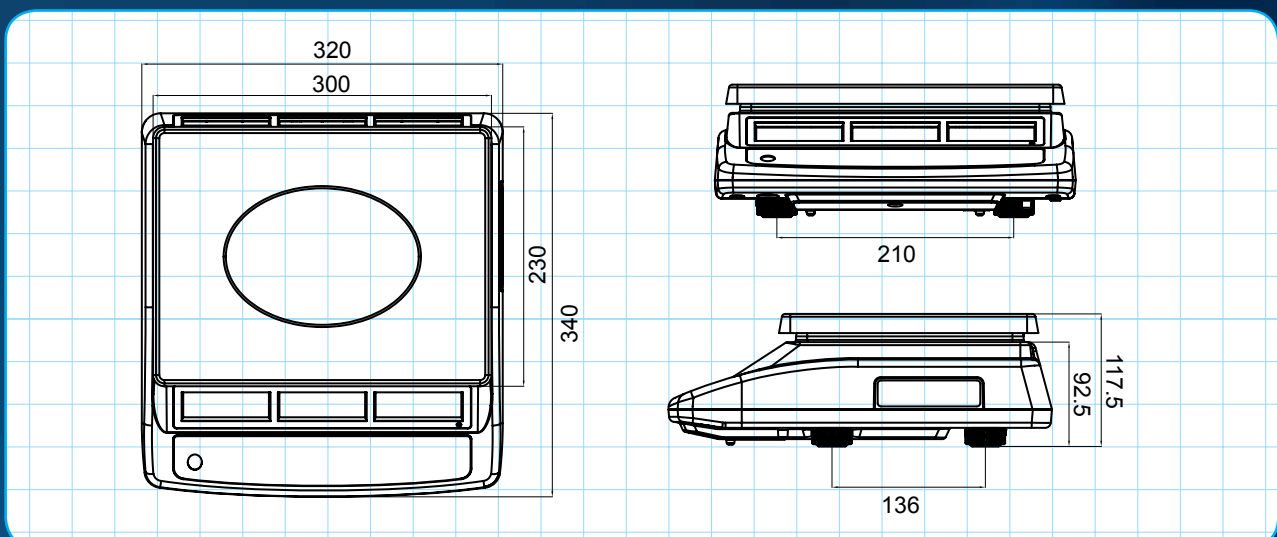



## Wombat Counting Scale

### Who is Australian Weighing Equipment & Rite-Weigh Scales

Jeff & Trevor Baillie started AWE in 1981, focusing on weighing solutions based on engineering principles. For the last 30 years AWE has built its reputation as a leading supplier of robust industrial weighing equipment and solutions provider. Our innovative engineering, and continuous product improvement have led to designs that will stand up to the rigours and demands your operators and machinery will throw at it.

If you need your weighing solution to stand up to punishing abuse, then you require 3 components: Strength, Reliability and Qualified Trades People/Service.

The biggest compliment we hear is, "Your weighing equipment is Over Engineered".

Our response, "AWE understands that most equipment operate in a rugged environment. They cop a pounding. We must engineer to survive these conditions, because our reputation depends on this. So we prefer to build based on our experience to anticipate overloading situation, to meet these demands. AWE's equipment are built to "Our Standards" to protect your investment.

You can choose from our standard model or consult with our inhouse engineers, design and manufacturing facility, together with our network of consultants and agents around the world, we are able to offer a complete custom built solution for your weighing needs.

### AWE Investment in the Future

To help provide a seamless packaging solution, AWE has just increased its investment in our manufacturing facilities now giving us over 3,200m<sup>2</sup> of factory in Sydney with

- ▶ A CNC Machine Shop
- ▶ Heavy Metal Fabrication Shop
- ▶ Plus further room for our team of qualified tradesman

Acquisitions of Bradwood Packaging, Dendy Packaging and Design Engineering increased our packaging and engineering experience.

In 2008, AWE established a manufacturing facility in China - China Weighing and Bulk Materials Handling Equipment.

China Weighing and Bulk Materials Handling Equipment, currently occupies a purpose built 2,300m<sup>2</sup> factory in Suzhou China (70kms From Shanghai).

All Equipment is Australian designed and manufactured under AWE Group's strict quality control system in our own factories both locally and internationally.

### About Australian Weighing Equipment

Established in 1981 in Sydney, Australia, Australian Weighing Equipment engage in tireless research and development of industrial weighing equipment and design aiming to streamline your workflow logistics to save you time, labor and money. This innovation allows your company to manage your stocks or product with the latest development in digital technology.

For more than 30 years, AWE has served Australia and beyond for its trusted industrial

weighing equipment and technology. Recognised for its loyal and growing patronage, there isn't an industrial facility in Australia without an AWE trademark.

Customer satisfaction and repeat business is what we're all about. We have grown steadily to acquire a solid reputation for industrial weighing equipment suppliers. We are Australian Weighing Equipment, one of the world's largest manufacturers of commercial and industrial scales down under.

Australian Weighing Equipment Offers Industrial Weighing Solutions Built To Last

## Australian Weighing Equipment Guarantee

Australian Weighing Equipment supply and backup what they sell - That's a Guarantee from the manufacturer. The directors stand by all the Weighing Solutions sold by AWE. If it's not suitable, or doesn't work, then we will fix it, replace it or you don't pay.

To deliver on our commitment of providing quality, reliable weighing solutions, AWE understands it's more than just delivering a well built & designed weighing solution, it also requires a team of dedicated people who care and are there to back you up with great Service & Support.

The quality of our team sets us apart. Most companies choose to outsource these services to contractors, or buy machinery from overseas as a so called agent. They do not have the knowledge base to support or maintain their equipment long term.

AWE's solutions are designed to fit your factory systems, to do this requires a team of professionally trained tradesmen.

## We're Talking About

- ▶ Licensed Tradesmen
- ▶ Mechanical Engineers
- ▶ Electrical Engineers
- ▶ Structural Engineers
- ▶ Draftsmen
- ▶ Fitter & Turners
- ▶ Boilermakers
- ▶ Fully Qualified Scale Makers
- ▶ Electronic Technicians
- ▶ Instrument Fitters
- ▶ Electricians
- ▶ Service Technicians
- ▶ Project Managers
- ▶ Formworkers
- ▶ Concreters

They are all led by your own personal project manager assigned to make your project run smoothly. Which means there is one point of contact, you won't get the run around. They're responsible for managing the design team, installation, commissioning and documenting your project.

## Reliability

AWE industrial weighing systems are designed for Australian conditions and a lifetime of heavy duty weighing. Our proven and robust designs are engineered and manufactured in house, to the highest standards to provide our customers with a lifetime of reliable and accurate service.

In the unlikely case of breakdown, we know downtime is costly and service is required, quickly with accurate attention.

**AWE Technicians Are On Call 24/7 ,  
Because We Know Breakdowns Don't  
Always Happen In Business Hours.**

The service guys are there when you need them. When your line goes down, 5.00pm on a Friday, you need technicians to turn up. If you need them at 11pm Saturday, they will be there. That's a promise, because we stand behind our equipment.

## So If You Have Any Questions About Weighing Solutions, Then Talk To AWE.

AWE guarantees our solutions and products. From over 30 years experience manufacturing Weighing Systems, we're able to draw from our armoury. Instead of forcing your process to suit our solutions, we customise the solutions to suit your process.

AWE prides itself in providing plain english proposals, there's no hidden surprises. You'll know what you're getting.

So if you have questions about Weighing Solutions, then talk to AWE.

Call or email us today and find out how our sales team and project engineers can assist you in finding the best Industrial Weighing solution for your needs.



Visit AWE Group YouTube channel at [www.youtube.com/user/AustWeighing](http://www.youtube.com/user/AustWeighing) where you can watch videos on our products and services in action. You'll see our new product releases on Industrial Weighing Systems, Packaging Machinery & Bulk Handling Solutions

### Companies in the AWE Group



Australian Weighing Equipment P/L



All State Machining P/L



Rite-Weigh Scales P/L



Bradwood Packaging P/L



Dendy Packaging (Australia) P/L



China Weighing & Packaging Machinery

#### Australian Weighing Equipment Sydney Office

16 Kerr Road  
Ingleburn NSW 2565  
PH: (+61) 2 8717 3333  
Email: [sales@awe.com.au](mailto:sales@awe.com.au)  
[www.awe.com.au](http://www.awe.com.au)

#### Rite-Weigh Scales Melbourne Office

37 Barrie Road  
Tullamarine, VIC, 3043  
Ph: (+61) 3 9330 1011  
Email: [sales@rite-weigh.com.au](mailto:sales@rite-weigh.com.au)

#### Rite-Weigh Scales Brisbane Office

7 Darnick Street,  
Underwood, QLD, 4119  
Ph: (+61) 7 3423 1388  
Email: [sales@rite-weigh.com.au](mailto:sales@rite-weigh.com.au)



Sydney



Melbourne



Brisbane

#### Dealer's Information:

For Links to AWE Website please scan your smartphone here

